

PLAN VIEW

STANDARD PULLING IRON TYPICAL
OPPOSITE EACH WALL (4 TOTAL)
ANCHORED INTO FLOOR

SECTION A

12"Øx4 1/2" COPOLYMER
POLYPROPYLENE SUMP PAN
WITH LID (CENTERED)

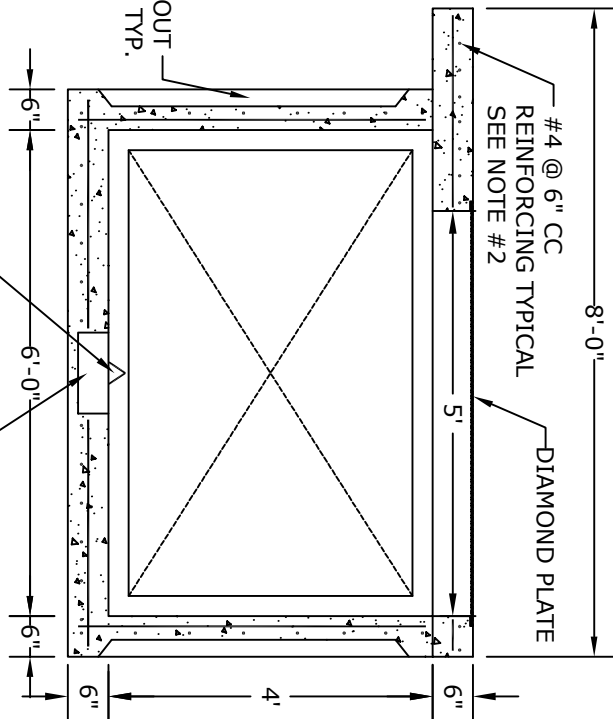
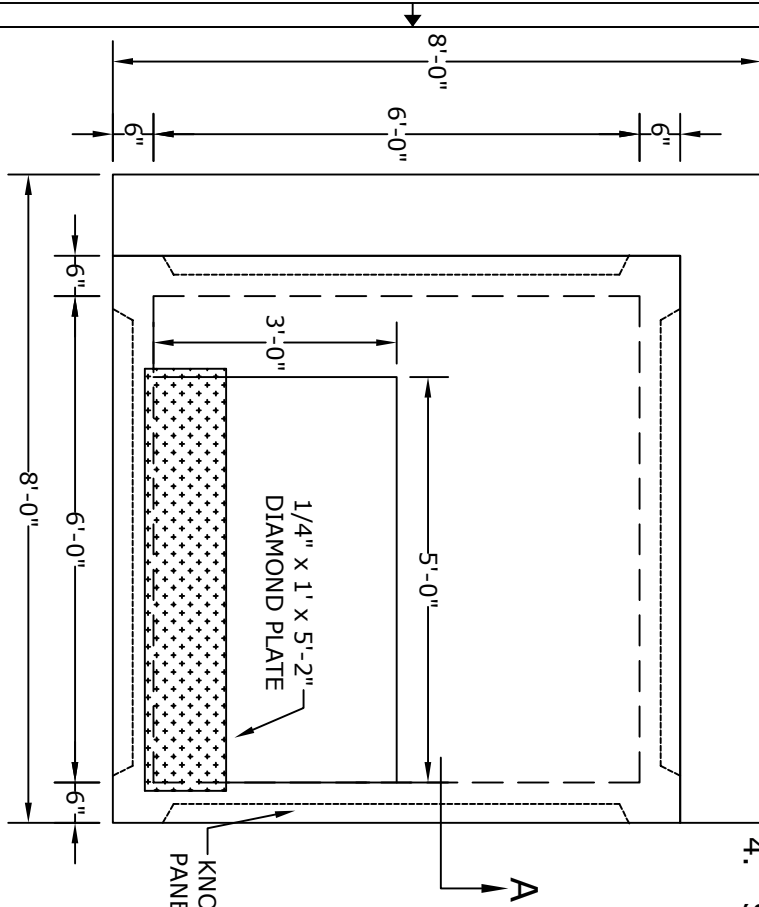

- NOTES**
1. CONCRETE - 4000psi, AIR ENTRAINED
 2. REINFORCING STEEL - GRADE 60, ASTM A-615
 3. WELDED WIRE FABRIC - 4x4xw4/w4 ASTM A-185
 4. SUMP PAN - 12"Øx4 1/2" COPOLYMER POLYPROPYLENE

ALTOMARE PRECAST, INC.
4300 Wissahickon Ave.
Philadelphia, PA 19129
Ph: 215-225-8800 Fax: 215-225-8900

TITLE:
6'-0"x6'-0"x4'-0" Vault
w/ 8'X8' Deck
Electrical Manhole

PROJECT:
CONTR:
DATE: