

7590Z 7590M5 7590P1 7590T1 Assembly

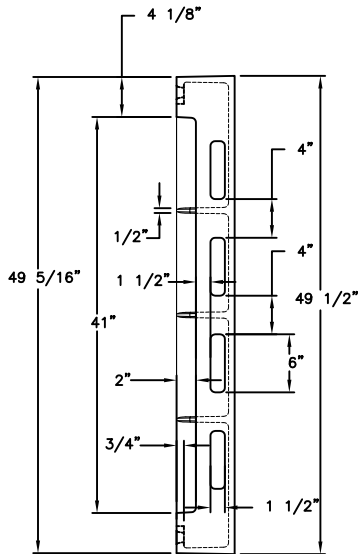

BACK ELEVATION

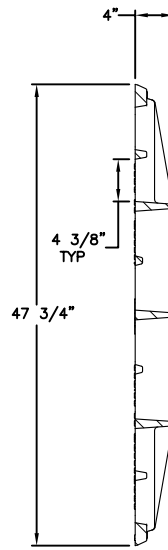
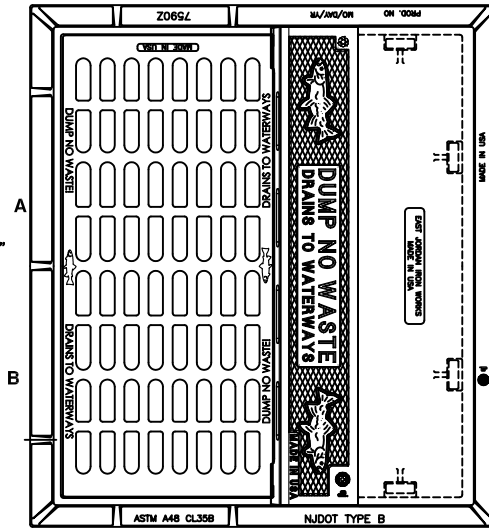

GRATE SECTION

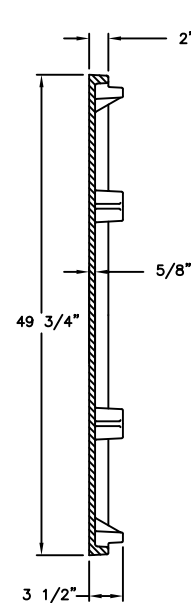
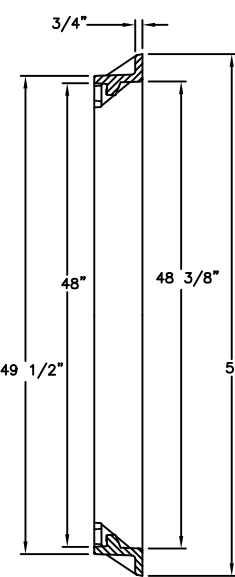
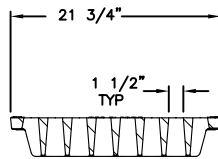

PLATE SECTION



FRAME SECTION



GRATE SECTION

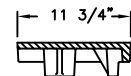
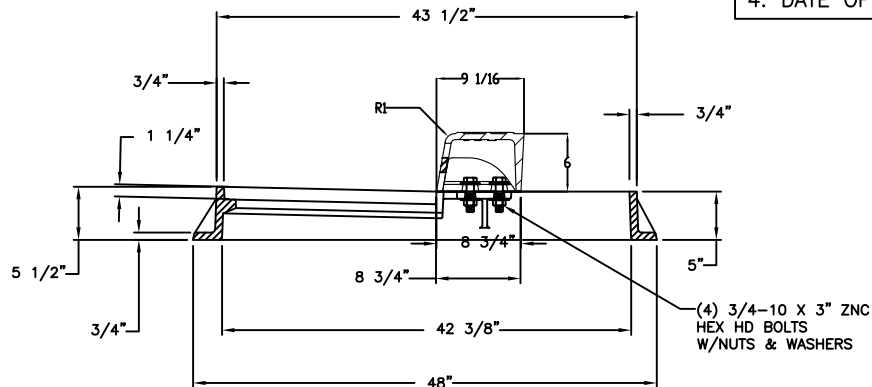

PLATE SECTION

GRATE SECTION PLATE SECTION FRAME SECTION

MARKINGS REQUIRED BY NJDOT & AASHTO M306-04:
 1. NAME OF PRODUCING FOUNDRY
 2. COUNTRY OF MANUFACTURE (MADE IN USA)
 3. ASTM A48 CLASS 35B
 4. DATE OF MANUFACTURE



FRAME & BACK SECTION

Product Number
00759128A02

Design Features

- Materials
 - Curb Inlet Frame
 - Gray Iron (CL35B)
 - Grate
 - Gray Iron (CL35B)
 - Hood
 - Gray Iron (CL35B)
 - Curb Inlet Plate
 - Gray Iron (CL35B)
- Design Load
 - Heavy Duty
- Open Area
 - 415 sq in
- Coating
 - Undipped
 - √ Designates Machined Surface

Certification

- ASTM A48
-
-
- Country of Origin:USA

Major Components

- 00759011
- 00759128
- 00759062
- 00759081

Drawing Revision

2/6/2013 Designer: DJH
Revised By:

Disclaimer

Weights (lbs./kg) dimensions (inches/mm) and drawings provided for your guidance. We reserve the right to modify specifications without prior notice.

CONFIDENTIAL: This drawing is the property of EJ GROUP, Inc., and embodies confidential information, registered marks, patents, trade secret information, and/or know how that is the property of EJ GROUP, Inc. Copyright © 2012 EJ GROUP, Inc. All rights reserved.

Contact

800 626 4653
ejco.com