

1040APT 1045ZPT Assembly

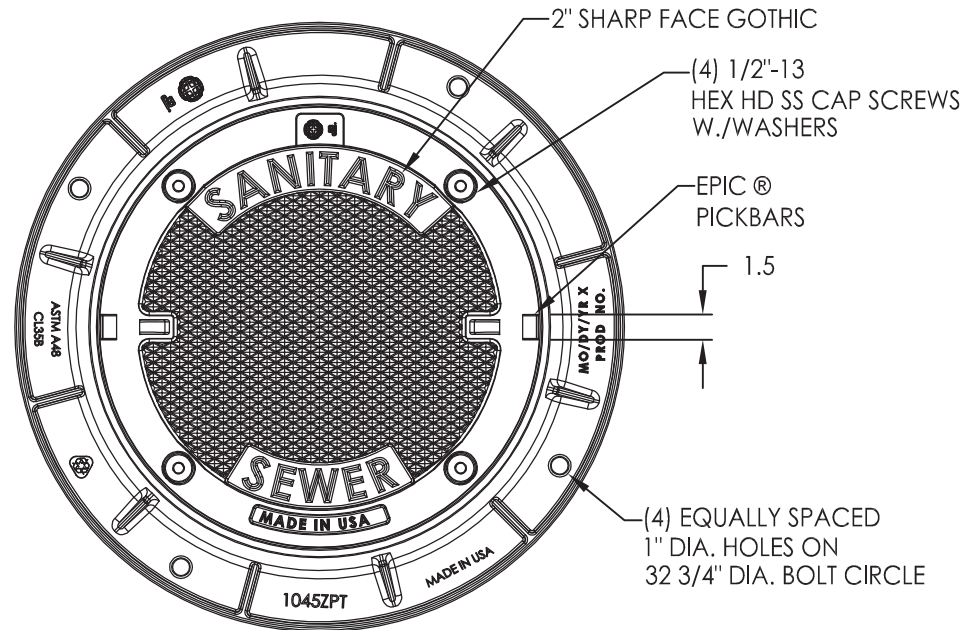

PLAN VIEW



COVER SECTION

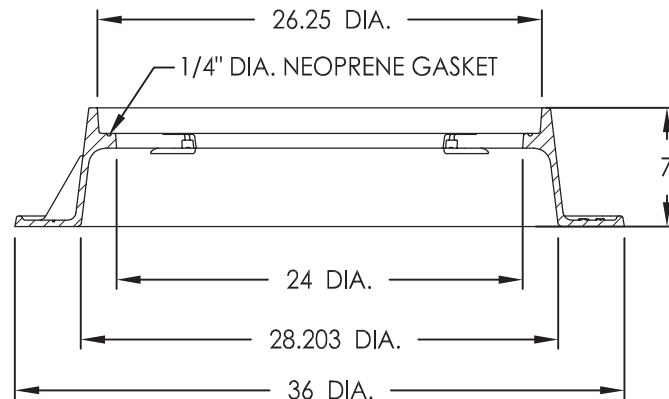

FRAME SECTION

Product Number

00104509

Design Features

- Materials
- Cover
 Gray Iron (CL35B)
- Frame
 Gray Iron (CL35B)

- Design Load
 Heavy Duty

- Open Area
 n/a

- Coating
 Dipped

- √ Designates Machined Surface

Estimated weight

- 267 lb.

Certification

- ASTM A48

-
-
- Country of Origin: USA

Major Components

- 00104174
- 00104512

Drawing Revision

- 9/1/2009 Designer: DVD
- 10/6/2017 Revised By: MAH

Disclaimer

Weights (lbs./kg) dimensions (inches/mm) and drawings provided for your guidance. We reserve the right to modify specifications without prior notice.

CONFIDENTIAL: This drawing is the property of EJ GROUP, Inc., and embodies confidential information, registered marks, patents, trade secret information, and/or know how that is the property of EJ GROUP, Inc. Copyright © 2012 EJ GROUP, Inc. All rights reserved.

Contact

800 626 4653
ejco.com