

PLAN VIEW

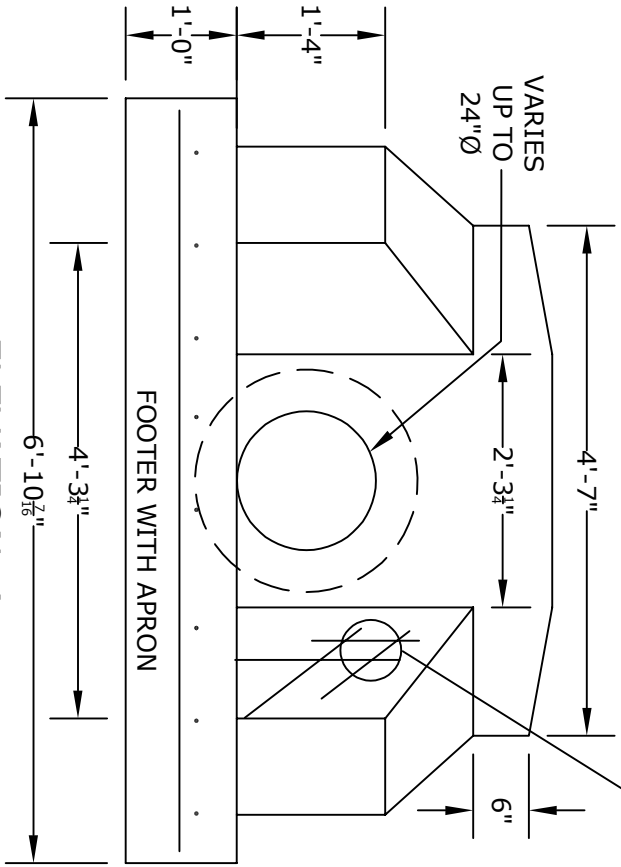

ELEVATION A



ENERGY DISSIPATER

NOTES

1. CONCRETE - 4000psi, AIR ENTRAINED
2. REINFORCING STEEL - GRADE 60, ASTM A-615
3. WELDED WIRE FABRIC - ASTM A-185
4. MATERIAL AND CONSTRUCTION SHALL COMPLY WITH PENN D.O.T. PUB. 408
5. ALL MATERIAL USED MADE IN THE USA

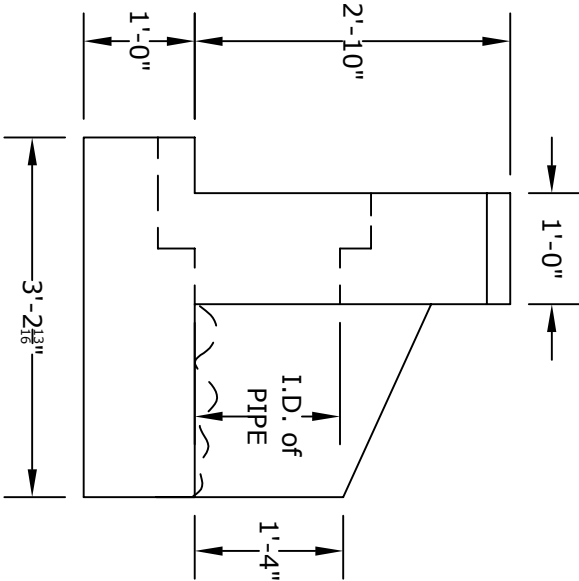

ELEVATION B

ALTOMARE PRECAST, INC.
 4300 Wissahickon Ave.
 Philadelphia, PA 19129
 Ph: 215-225-8800 Fax: 215-225-8900

TITLE:
**Small
 D-W Endwall**

PROJECT:
CONTR:
DATE: