

PENNDOT BIKE SAFE GRATE H-25

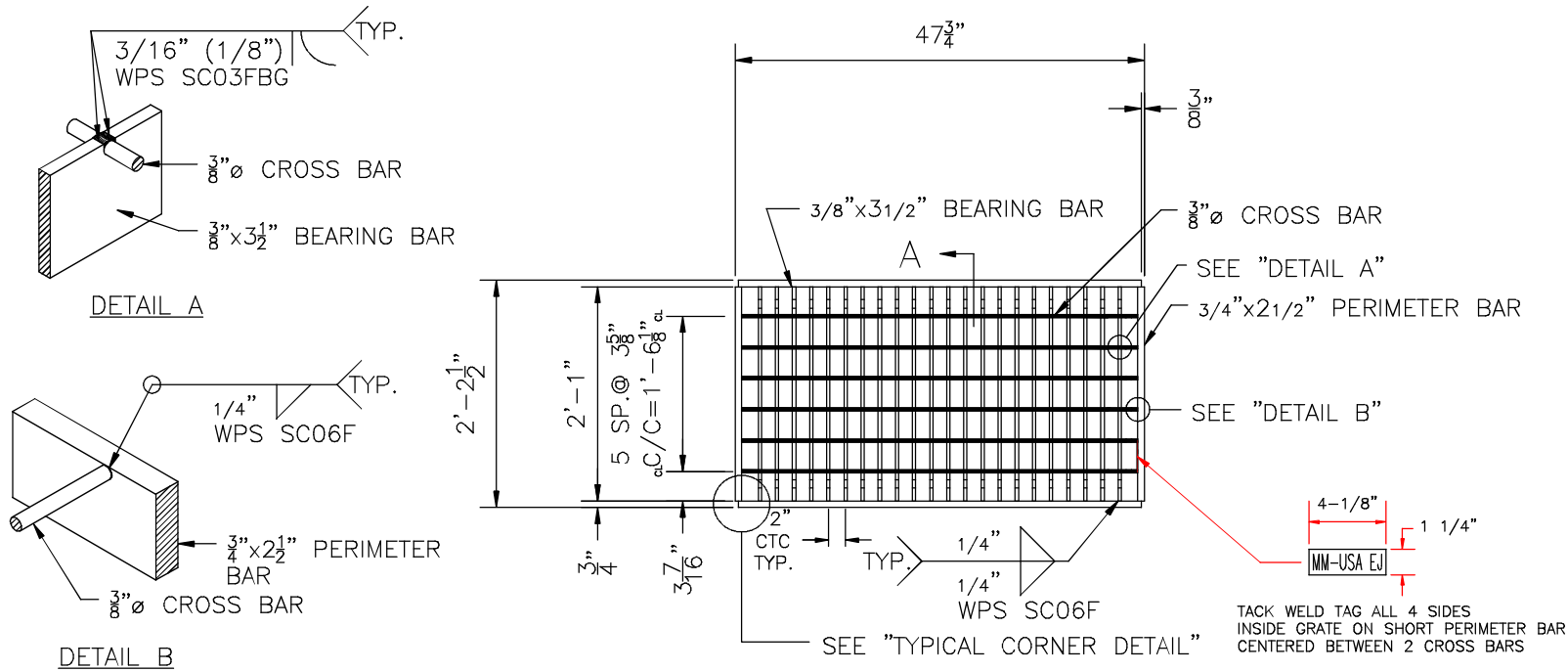

Product Number

PABKGR0808

Design Features

- Materials
See notes
- Design Load
Per PennDOT RC-45M
- Open Area
- Coating
Painted per RC-45M
- √ Designates Machined Surface

Certification

- WT: 279lbs
-
-
- Country of Origin: USA

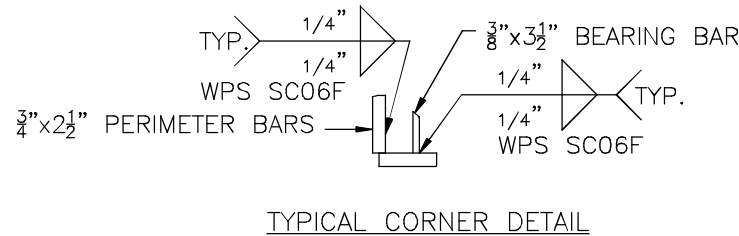
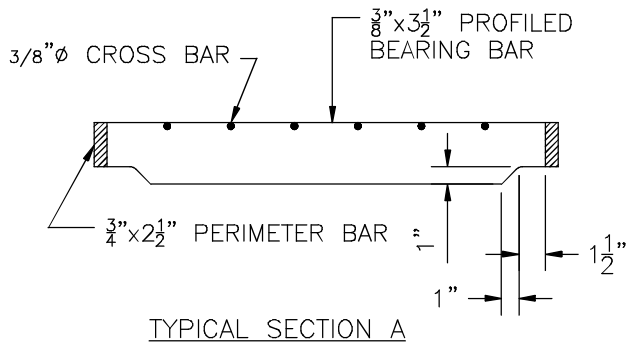

NOTES:

1. ALL BEARING BARS AND PERIMETER BARS SHALL CONFORM TO ASTM A709 GR. 50 (A572) STEEL.
2. ALL CROSS BARS SHALL BE LOCATED FLUSH ALONG THE TOP SURFACE OF THE GRATE.
3. ALL WELDING SHALL BE IN CONFORMANCE WITH THE REQUIREMENTS OF PUBLICATION 408, SECTION 1105.03(m).
4. COAT GRATES WITH AN APPROVED BITUMIOUS PAINT, IN ACCORDANCE WITH PUBLICATION 408, SECTION 605.2(f).
5. ENTIRE GRATE SHALL CONFORM TO THE REQUIREMENTS OF PENNSYLVANIA DOT STANDARD RC-45M.

Drawing Revision

09/23/14 Designer: DM
08/31/15 Revised By: TYM

Disclaimer

Weights (lbs/kg), dimensions (inches/mm) and drawings provided for your guidance. We reserve the right to modify specifications without prior notice.

CONFIDENTIAL: This drawing is the property of EJ Group, Inc. and embodies confidential information, registered marks, patents, trade secret information, and/or know-how that is the property of EJ Group, Inc. Copyright © 2011 EJ Group, Inc. All rights reserved.

Contact

800 626 4653
ejco.com