

SECTION A

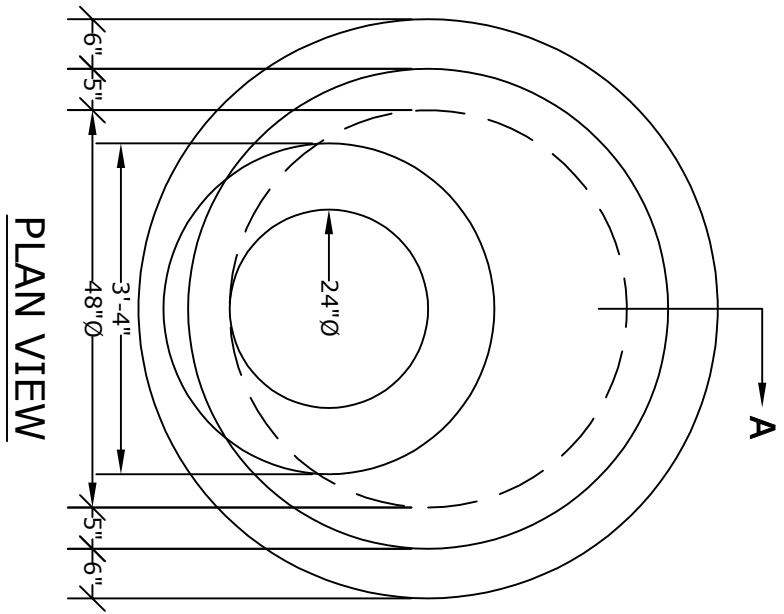

PLAN VIEW

- NOTES**
1. CONCRETE- 4000psi, AIR ENTRAINED
 2. REINFORCING STEEL- GRADE 60, ASTM A-615
 3. WELDED WIRE FABRIC- 3x12xw3/w2 ASTM A-185
 4. LADDER RUNGS- COPOLYMER POLYPROPYLENE PLASTIC w/1/2" REBAR, GRADE 60
 5. MATERIAL AND CONSTRUCTION SHALL COMPLY WITH PENNDOT PUB. 408, 72, RC39, & A.S.T.M. C478, C890, C913, C1443 and C1557
 6. FRAME AND COVER- SEE ACCOMPANYING SPEC. SHEET
 7. ALL MATERIAL USED MADE IN THE USA

ALTOMARE PRECAST, INC.
 4300 Wissahickon Ave.
 Philadelphia, PA 19129
 Ph: 215-225-8800 Fax: 215-225-8900

TITLE:
 4'Ø Philadelphia
 Storm/Sanitary MH

PROJECT:
 CONTR:
 DATE: